

GP-12/16

Perforator



GP-12/16

Perforator



With Adjustable Feed Opening

GP-12

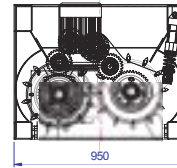
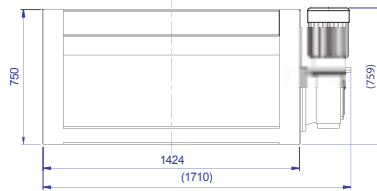
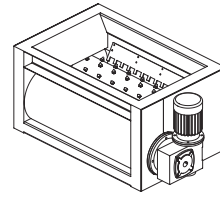
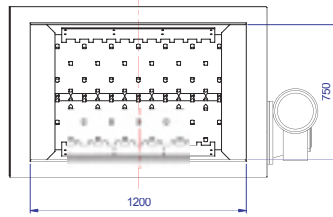

GP-16

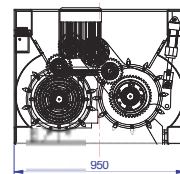
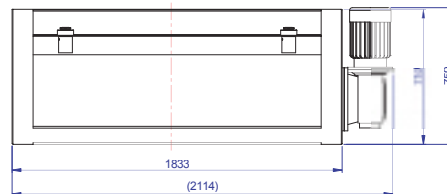
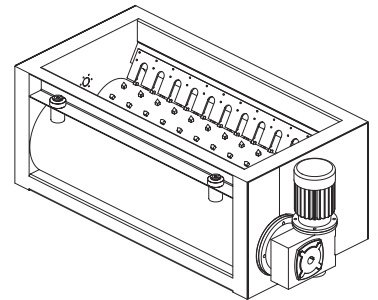
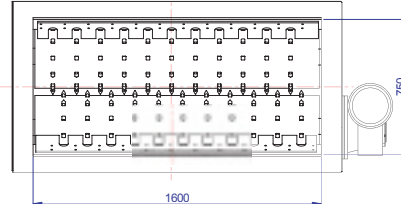

Specifications:

TYPE	GP-12 / GP-16
Horsepower	5 HP
Gear Ratio	1 : 6
Drum Speed	50 rpm
Feed Opening Dimensions (mm)	1200 x 750 / 1600 x 750
Max bottle type (mm)	5 litres